



SPEED QUEEN | PROFESSIONAL

Washer-Extractor & Dryer for OPL

SF

SD

Best-in-class Quantum® Gold Controls

Revolutionary Quantum® Gold technology combines equipment controls, programming and wireless networking into one full-store management system, including: wireless networking, adjustable water levels and in-depth reporting. Designed to reduce costs and maximize revenue, Quantum gives you the power to achieve unprecedented levels of profitability.

Washer-extractors features

- Stainless steel outer and inner drum
- Industry-leading 440 G-Force extraction removes more moisture, minimizing drying times and utility costs
- Totally freestanding: can be installed on any floor and any level
- Suspension with new out-of-balance logic
- Soap box with four compartments
- Door opens 180° for easy loading and unloading
- Available with drain pump or drain valve
- Top, Front and side panels standard available in anthracite grey or in Stainless steel front & top panels.
- Electrical heating or boiler-fed
- Soap supply injection allows easy connection with liquid soap pumps
- Longer lifetime: at least 15,000 cycles

Dryers features

- Galvanized steel cylinder
- Oversized lint filter located in front for easy cleaning
- Powerful exhaust blower assures short drying times and low operating costs
- Wide door opening of 180° for easy loading and unloading
- Top, Front and side panels standard available in anthracite grey or in Stainless steel front & top panels
- Electrical or gas heating

Quantum Controls

- 4 drying programs
- LED notification
- Programmable by Infra Red



Quantum Controls

- 6 programs
- 3 cycle modifiers
- LED notification
- Programmable by Infra Red
- Time remaining countdown



Connectivity

Wi-fi connectivity via accessory, enabling access to Speed Queen Insights and Speed Queen App.

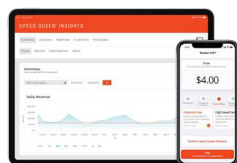

Fast cycles



Electronic Controls



Best Warranty



Lasts Longer



Washer-extractor

Specifications



	SF						
	MARKET	VOLTAGE	CONTROL LOCATION	COLOR	BASKET	DRAIN	CAPACITY
SF3JGBSP403UN01	Europe/CE	400v/50Hz/3N	45° front control	Stainless	Stainless	Pump	9,5 kg
SF3JGBSG403UN01	Europe/CE	400v/50Hz/3N	45° front control	Stainless	Stainless	Gravity drain	9,5 kg
SF3JGBSP403UG01	Europe/CE	400v/50Hz/3N	45° front control	Grey	Stainless	Pump	9,5 kg
SF3JGBJP403UG43 ¹	Europe/CE	400v/50Hz/3N	45° front control	Grey	SS w/ injection	Pump	9,5 kg
SF3JGBSG403UG01	Europe/CE	400v/50Hz/3N	45° front control	Grey	Stainless	Gravity drain	9,5 kg
SF3JGBJG403UG431	Europe/CE	400v/50Hz/3N	45° front control	Grey	SS w/ injection	Gravity drain	9,5 kg
SF3JGBSP403NG22	No agency	230v/50Hz/1N	45° front control	Grey	Stainless	Pump	10,5 kg

¹ Soap Supply System

Washer Extractor		
DRUM VOLUME	l	96,8
TYPE OF CONTROL		Quantum
MOTOR		
Frequency controlled	kW	0,67
EXTRACTION SPEED	rpm	1200
G-FACTOR		440
ELECTRICAL HEATING		
Electrical	kW	4,8
DIMENSIONS		
H×W×D	mm	1027×683×704
Net weight	kg	113
TRANSPORT DATA		
Volume (packed)	m ³	0,71
Packed H×W×D		1150x760x860
Gross weight	kg	122
Ratio 1:9	kg	10,5

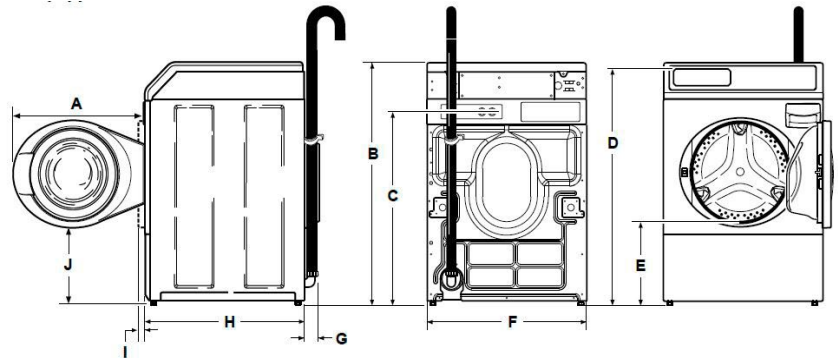

	A	B	C	D	E	F	G	H	I	J
mm	611	1027	813	1006	371	683	52	704	40	333

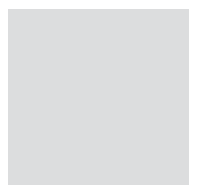

Dryer

Specifications



SD							
	MARKET	ACTUATION	HEATING	VOLTAGE	CONTROL LOCATION	COLOR	BASKET
SDGNLBGS303UG01	Europe/CE	OPL ¹ / PCP ²	Gas	230v/50Hz/1N	45° Front	Stainless	Galvanized
SD3NLBGS403UN01	Europe/CE	OPL ¹ / PCP ²	Electric	400v/50Hz/3N	45° Front	Grey	Galvanized
SDENLBGS303UG01	Europe/CE	OPL ¹ / PCP ²	Electric	230v/50Hz/1N	45° Front	Grey	Galvanized
SD3NLBGS403UG01	Europe/CE	OPL ¹ / PCP ²	Electric	400v/50Hz/3N	45° Front	Grey	Galvanized
SDENLBGS543ZG01	Universal IEC	OPL ¹ / PCP ²	Electric	220v/60Hz/1N	45° Front	Grey	Galvanized
ND3NXAGS403UN01	Europe/CE	OPL ¹ / PCP ²	Electric	400v/50Hz/3N	45° Front	Stainless	Galvanized

¹ On Premise Laundry

² Prep for Central Pay

Dryer		
DRUM VOLUME	l	198
CAPACITY	kg	8,2
TYPE OF CONTROL		Quantum
ELECTRICAL HEATING	kW	5,2 (230V) 5,3 (400V)
GAS HEATING	kW	7,3
BASKET		Galvanize
DIMENSIONS		
H×W×D	mm	1027×683×711
Net weight	kg	68
TRANSPORT DATA		
Volume (packed)	m ³	0,71
Packed H×W×D		1150x760x860
Gross weight	kg	73
Ratio 1:19	kg	10,5

