



FS800 | FS1000 | FS1200

INDUSTRIAL HIGH SPIN WASHER-EXTRACTORS



TOUCH CONTROL AVAILABLE
Multilingual user-friendly 7" touch control



CLOUD-BASED PLATFORM
to easily monitor your laundry everywhere and at any time



IMPROVED DURABILITY
for your peace of mind with a 3-year warranty



AUTOMATIC WEIGHING SYSTEMS
Automatically adapts amount of water and detergent based on the wash load



AIR OPERATED WATER INLETS AS STANDARD
For shorter wash cycles

FEATURES & BENEFITS

Features

- Freestanding, high spin washer
- Stainless steel cabinet, drum and tub
- Patented soap hopper with 5 removable compartments
- Easy access to all vital parts from the front
- Large door opening for easy loading & unloading
- Two large drain valves (Ø 103 mm)
- USB plug located on the main board
- Frequency controlled motor
- Perforated lifting ribs: more mechanical action, lower water consumption
- Air operated water inlet and drain valve
- Manual weighing system

Options

- Liquid soap connection and pumps
- 3rd water inlet
- Recycle drain valve
- Insulation for energy and heat & noise reduction
- Automatic weighing system through 4 weighing cells
- Tilting system on pneumatical basis: assists operators during loading & unloading

Control

- XControl FLEX PLUS – fully programmable and customizable cycles 7" touch screen.
 - User-friendly screen with operating instructions built in as part of the control
 - Complete control content available in 34 languages
- XControl – fully programmable control with 20 Pre-set programs and memory up to 99.

SPECIFICATIONS

TYPE		FS800	FS1000	FS1200
INNERDRUM				
Capacity 1:09	kg (lb)	89 (196)	108 (238)	128 (282)
Capacity 1:10	kg (lb)	80 (176)	97 (214)	115 (253)
Volume	litres	807	972	1154
Diameter	mm	1110	1200	1300
DRUM SPEED				
Wash	rpm	36	33	32
Extraction	rpm	750	720	695
G-FACTOR		350	350	350
HEATING				
Electricity	kW	67,5	-	-
Steam	bar	3 - 8	3 - 8	3 - 8
	psi	44 - 116	44 - 116	44 - 116
Hot water	°C	194	194	194
Sound pressure level	dB (A)	< 71	< 72	< 72
Electrical connection		3x380-480V 50/60Hz 3x208-240V 50/60Hz, 3x 440-480V 50/60Hz		
Water valves connection	BSP	1 1/2"	1 1/2"	1 1/2"
Water inlet	inch	3x1 1/2"	3x1 1/2"	3x1 1/2"
Steam inlet	inch	1"	1"	1"
Compressed Air inlet	mm	Ø 8	Ø 8	Ø 8
Drain	mm	2x103	2x103	2x103
		2x4"	2x4"	2x4"
DIMENSIONS				
Size H×W×D	mm	2059×1495×1925	2060×1790×2024	2093×1855×2111
Net weight	kg	2640	3170	3480
TRANSPORT DATA				
Packed H×W×D	mm	2325×1780×2150	2425×2080×2350	2425×21805×2350
Gross weight	kg	2830	3410	3710

DIMENSIONS

	A	B	C	D	E	F	G	H	I	J	K	L	M	N	O	P	Q	R	S	T	U	V	W	X	Y	Z
FS800	1495	2059	1940	1390	1130	800	295	168	125	125	90	100	83	210	1868	1763	1955	1460	276	426	634	707	197	380	665	1759
FS1000	1790	2060	2005	1688	1212	882	214	232	125	125	124	148	83	210	1868	1758	1950	1754	304	454	696	768	197	527	650	1836
FS1200	1855	2093	2085	1754	1225	825	342	247	125	125	120	148	83	210	1868	1758	1980	1820	264	415	722	795	197	562	757	1866

width height depth

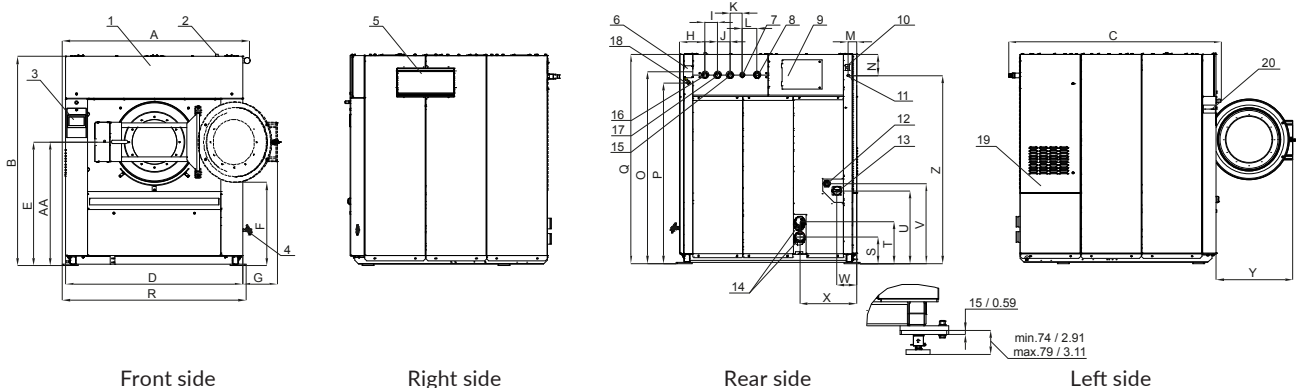

- | | | |
|--|--|--|
| 1. Box of electrical components | 8. Tub ventilation (refer to row Z) | 15. Hot water inlet (refer to row Z) |
| 2. Soap dispenser ventilation | 9. Cover for pneumatic components | 16. Soft cold water inlet (refer to row Z) |
| 3. Control panel | 10. PC programming connection RS485 (on request) | 17. Hard cold water inlet (refer to row Z) |
| 4. Drain valve for wash bath sample (on request) | 11. Compressed air inlet | 18. Hose connection soap supply (refer to row P) |
| 5. Soap dispenser | 12. Entry main power cable | 19. Electric switchboard cover |
| 6. Electrical signals liquid soap | 13. Main switch | 20. Serial plate |
| 7. Steam inlet (refer to row Z) | 14. Drain outlet | |

Certified by ISO9001 and 14001

