



MXB360 | MXB500 | MXB700
BARRIER WASHER-EXTRACTORS



TOUCH CONTROL AVAILABLE
Multilingual user-friendly 7" touch control



CASCADE DRUM TECHNOLOGY
Extra mechanical action thanks to its cascading shape of the surface



CLOUD-BASED PLATFORM
to easily monitor your laundry everywhere and at any time



AUTOMATIC WEIGHING SYSTEMS
Automatically adapts amount of water and detergent based on the wash load



IMPROVED DURABILITY
for your peace of mind with a 3-year warranty

FEATURES & BENEFITS

Features

- Freestanding, high spin
- Stainless steel top, drum and tub and full stainless steel cabinet
- Patented soap hopper
- Frequency controlled motor
- Perforated lifting ribs: more mechanical action, lower water consumption
- Easy access to all vital parts
- Large door opening for easy loading & unloading
- Golden lock - patented inner door lock mechanism
- Large drain valves (2 x Ø 76 mm)

Options

- Liquid soap connection and pumps.
- Water recovery kit and sample tap
- Steam heating version
- Insulation for energy, heat and noise reduction
- Version without soap hopper
- Drain valve for water recycling
- Air operated water inlets
- Second display (located on the clean side)
- Extra visualisation of end of cycle (orange light + signal)
- Tilting system: assists operators during loading & unloading.

Control

- XControl FLEX PLUS – fully programmable and customizable cycles 7" touch screen.
 - User-friendly screen with operating instructions built in as part of the control
 - Complete control content available in 34 languages
- XControl – fully programmable control with 20 Pre-set programs and memory up to 99.

SPECIFICATIONS

TYPE		MXB360	MXB500	MXB700
INNERDRUM				
Capacity 1:09	kg (lb)	40 (88)	55,5 (122)	78 (172)
Capacity 1:10	kg (lb)	36 (79)	50 (110)	70 (154)
Volume	litres	360	500	700
Diameter	mm	775	775	775
Depth	mm	764	1060	2 x 742
DRUM SPEED				
Wash	rpm	41	41	41
Extraction	rpm	900	900	900
G-FACTOR				
		350	350	350
HEATING				
Electricity	kW	36	48	60
Steam	bar	1 - 8	1 - 8	1 - 8
Hot water	°C	90	90	90
Sound pressure level	dB (A)	< 68	< 69,9	< 69
Water valves connection	BSP	3x 1"	3x 1"	3x 1"
Water pressure	kPa	100-600	100-600	100-600
Rec. water pressure	kPa	300-500	300-500	300-500
Water inlet	l/min	20	20	20
Drain valve	outer Ø mm	76	76	76
Flow amount with drain valve	l/min	2 x 210	2 x 210	2 x 210
Steam valve connection	BSP	3/4"	3/4"	3/4"
Steam pressure	kPa	100-800	100-800	100-800
DIMENSIONS				
Size H×W×D	mm	1700 x 1270 x 980	1700 x 1566 x 980	1700 x 2032 x 980
Net weight	kg	960	1130	1310
TRANSPORT DATA				
Packed H×W×D	mm	2005x1530x1255	2005x1830x1255	2005x2290x1255
Gross weight	kg	1090	1280	1470

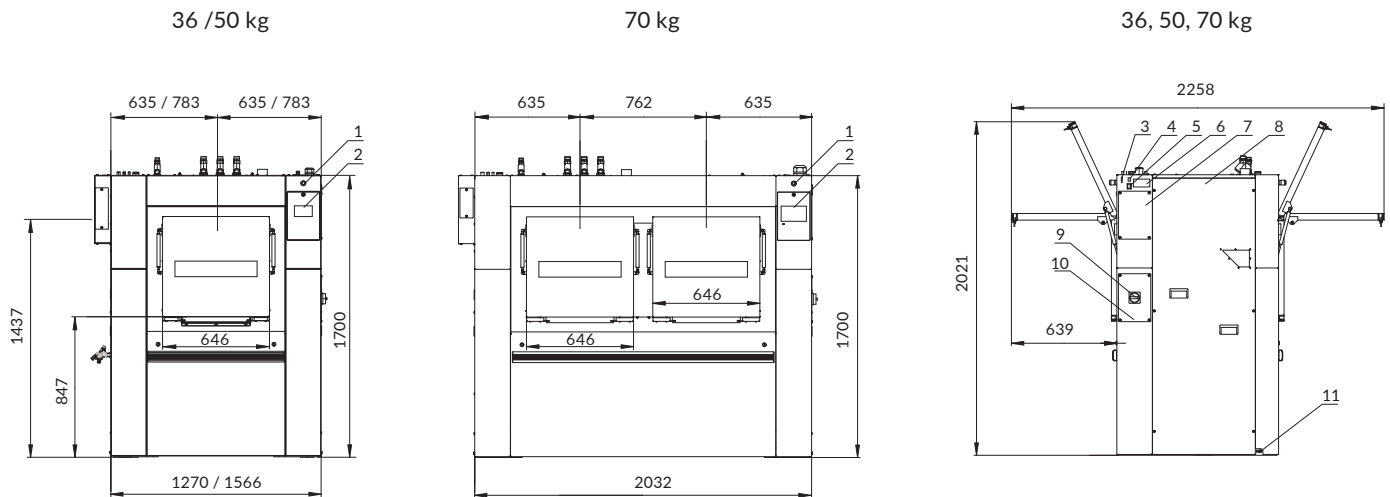

1. Emergency stop
2. Control panel
3. USB Port
4. PC Programming Connection

5. Switch: Steam / Electric Heating
6. Serial Plate
7. Electrical Signals Liquid Soap Cover
8. Electrical Components with Frequency

9. Inverter Cover
10. Main Switch Cover
11. Main Switch
12. Equipotential Bounding Terminal